

# **NorCal QRP Club Forty-9er**

**A 40M Direct Conversion Transceiver with 9V**

**Designed by Wayne Burdick, N6KR  
Manual by Doug Hendricks, KI6DS**

Thank you for purchasing the 4ger kit from NorCal QRP Club. As you will read in the following article, this rig was designed as a building project that was to be simple, yet provide a very usable transceiver when you were finished with it.

We first provided only a circuit board and a source for the crystal, but our members immediately deluged us with requests for a kit. Many of our members do not live near, nor do they have access to, a reasonable supply of parts. Thus they must resort to ordering from mail order companies. Most of the parts can be obtained from Mouser and Digikey, but the problem is that when you order from these companies, you have a minimum order charge of \$25. Thus you are either forced to order more parts than you need, or pay the \$25, which makes the parts very high for this rig.

NorCal has the advantage in being able to purchase in large quantities and our members thus gain the benefits. So, we are able to offer the complete kit; board, board mounted parts, and crystal for \$25.00 postage paid in the US, (DX orders add \$5 shipping).

We feel that this project will become an ideal first kit for all of those who have never built anything before. If you are in that category, we suggest that you find someone who knows how to solder. Have them teach you the proper method, and have them watch as you learn the technique. Several experienced kit builders suggest that you use a 25 Watt iron with a fine tip. This will be perfect for the 4ger. We also suggest that you buy Kester 63/37 solder with type 66 flux. Type 44 flux will also work. We prefer the type 66 because it is water soluble, and cleans up easier. Get the solder in the .031 diameter. It is much easier to work with. No matter what solder you purchase, make sure the solder you use has a resin core and is designed for electronics work.

The first step is to read the article by Wayne Burdick. N6KR. Wayne is one of the premier designers of QRP gear in the world. He is famous for his NorCa140, Sierra, and KC-1 keyer. All of these are now marketed by Wilderness Radio (415-494-3806), and if you enjoy building and working with the 49er, you will love the pleasure that you get in building other Burdick designs. Reading the article will give you the background and help you understand how the 49er works.

Your second step is to inventory and identify the parts in the kit. This process is very important, as the radio will not work unless you have the correct parts in the right places on the board. NorCal has produced over 1000 kits, and the number one problem, far and away, is the inability to identify parts. Don't be intimidated or embarrassed. All of us were in your shoes at one time, as we are not born with the ability to identify electronic parts. We have produced a parts list with drawings and a description of each part so that you will be able to identify and learn what each part is. We are ready to open the envelope of parts and identify them at this time.

Get a piece of 8.5" x 11" plain white paper. Place the paper on a table and carefully pour out the parts on it. Separate the parts into similar piles (ones that look the same). Use the parts identification chart on page 5 and identify all of the parts. You may need a magnifying glass to clearly read the markings.

Write the part number and identifier (i.e. C7) on the paper and place the part on the paper beside it. Do it in order so you will be able to find the part when it is called for in the instructions.

Once you have identified the parts, it is time to start building. First, examine the pboard for shorts or bridges. I do this with an ohm meter set to an audio tone for a direct short. I then test each run to see that it is not shorted across the lands. This will make trouble shooting much easier later on. When you are satisfied that the board has no shorts, it is time to heat up the soldering iron and start "stuffing parts".

I like to use the schematic as I build. Most of the guys who are successful builders do the same thing. If you have never built before, this will be good training. If you have built before, please try building with the schematic as you go, and you will find that you will learn more as you build.

What do I mean by build by the schematic? I make a zerox copy of the schematic and lay it next to my work area. As I install parts I check them off the schematic by drawing a circle around them with a red ink pen. This keeps me from leaving out parts, or installing them in the wrong place. I check the board to make sure that the part I am installing goes where the schematic says it should BEFORE I solder.

First solder the NE602AN into the space marked UI on the board. Make sure that you have the notched end oriented the same as the outline on the silkscreen. This will insure that the pin orientation is correct. Now turn the board over and solder the 8 pins, being careful to not heat up the IC too much by leaving the iron on the joint too long. Hold it there long enough to melt the solder and make it flow into a good joint, but don't overheat the chip.

Next, do the same thing with the LM380N-8. Be sure to have the correct orientation with the chip. Also, solder all pins, even those that have no connections.

Now we are ready to install the 4 jumper wires. They are marked J1,2,3 & 4. I use resistor and capacitor leads that I have trimmed from parts that I have installed. If you do not have any laying around, trim the leads on a couple of the capacitors with long leads to 1/2 inch long. Take the piece of wire that you have cut off and use them for jumpers. Put the wire in one of the holes, bend it over flat on the board, and then pick up the wire with a pair of needle nose pliers where it should bend to go in the other hole. Take the wire out of the board, bend it at the correct place and then see if it fits so that the wire will lay flat on the board. If it does not lay flat, rebend the wire until it does. It is important that jumper wires lay flat on the board. By

By the way, the reason there are jumpers on the board is that I was not able to get all of the traces to go where they needed to go, so I had to use jumpers.

We will install the RFC's next that lay against the board. They look like resistors, but they have green bodies instead of white or tan. We will not install RFC2 at this time. Be sure that you identify them correctly from the parts identification page.

To install the inductors, bend the lead right at the edge where it goes into the body, and then place in the appropriate holes. Turn the board over, and then bend the leads 45 degrees so they will hold the part against the board. I like to mount my resistors and inductors flat against the board, and this is how I do it. Solder both ends of the inductor, and then trim the leads against the solder with side cutter pliers. Please be careful and hold the lead you are cutting to keep it from flying across the room.

Now we are ready to install the resistors. Identify them with their color code, and check with an ohm meter to make sure that you have the correct value. Resistors are installed the same way that inductors are. Be sure to trim the leads of each resistor as you install it. Install all resistors at this time, including variable resistor RI. It is the round one with 3 leads and has a silver and white body.

Our next step is to install the two diodes; DI and D2. They are both the same, so it doesn't matter which one you use where, but it most definitely matters that you orientate the diode in the correct position. The black band is the cathode (negative) end of the diode and goes the same direction as indicated on the silk screen.

Now install the 3 transistors, Q 1, Q2 and Q3. Q3 is shipped with a heat sink. Please remove it as it will not fit on the transistor on this board layout. Remove the heat sink before you install the transistor on the board. Make sure that you follow the orientation drawing on the board so that the transistors will be installed correctly. Clip the leads of the transistors after you have soldered them.

Find the 78L05, which is the voltage regulator and with a pair of needle nose pliers flatten the three leads so they are in line. Then install the voltage regulator.

We will now start with the installation of the capacitors. The mono caps will be installed first as they are the smallest and hardest to handle. Put them in their appropriate holes, and use the "bend at a 45 degree angle" trick you have learned to hold the caps while you solder them. Don't use your fingers as the cap will get hot and burn you. I like to mount my caps about 1/8" above the board, with the identifier all facing the same direction on the board. It really doesn't matter, but Chuck Adams, K5FO does it and his boards are beautiful. There is a simple beauty in neatness and conformity. After you have installed the 6 brown mono caps; C3, C5, C11, C15, C16, and C19, find the blue mono and install it. It is C 10.

The next caps to install are C1 and C7, the 22pF NPOs. Then install C5 and C14, the 82pF NPOs. Then C20, the 150pF NPO. Then solder in C4, the 270pFNPOs.

This kit uses a trimcap that is different than the one suggested by Wayne when he designed the circuit. It is easier to tune, and was cheaper, so we went with it. The only problem

is that Wayne wanted a variable cap that was 9-50pF in range. The gray tuning cap used in the kit goes from 4.5 to 60 pF. This results in the oscillator not oscillating when you tune to the low end of the capacitor. So, we use an old trick, we use a 5pF padding capacitor in parallel with the tuning cap. This results in adding 5pF to the Tuning cap spread so it is now effectively 9.5 to 65pF, close enough that it works fine. This is capacitor C21 that is not in the schematic. (Hated to spoil your fun looking for it, but I am trying to train you to use the schematic and I don't want to frustrate you.) Install C21 now. NOTE: If you are using Rev. A pc board there are no holes for C21. You can put it in the holes for C6, using the one nearest the crystal and one of the two side ones, or you can tack it on the bottom of the board. I think it looks much neater in the holes beside C6. Don't solder C21 until you have placed C6 on the board. You will solder both C21 and C6 at the same time.

Find the green trimcap, the one with 2 leads that are bent slightly. This is C2 and is used to peak the receiver, the only alignment the kit needs. Solder it in.

You will notice that we are building the board in layers, installing the parts that fit closest to the board's surface first.

We are ready to start with the taller components now. The first one is C6, which is the gray tuning cap discussed earlier. Be sure that it sits flat against the board.

We will next install the crystal, and here you have some room to customize your kit a little. If you have more than one rig that uses a crystal, it is nice to not have to buy a \$3.00 or more crystal for each radio. What I do is use a crystal socket for each rig and then plug the crystal in and out as I need it. But wait, you say, crystal sockets are just as expensive as crystals and much harder to find.

That is not true, because you can make your own crystal socket very easily and it costs almost nothing. Denis Englander, KC6EDI, one of our NorCal members came up with this neat idea. Use an IC socket. How? Cut the socket in half, and then cut 3 pins off the socket. Clip the middle pin and voila, you now have a crystal socket with 0.2" spacing, just right for your crystal. The machined crystal sockets work the best, and if you are careful you can get several crystal sockets out of one IC socket. Use a small file to smooth up the edges. I use an Exacto knife to cut and trim mine. Solder the socket in and now you don't have to have a separate crystal for all of your rigs. Great idea from a great guy, Denis Englander.

If you chose not to put the socket in for the crystal, then just solder in the crystal. Make it fit flush with the board.

Now we will install the electrolytic capacitors. The capacitors have a positive and a negative polarized lead: The negative lead is the one that is the shorter of the two, and has a strip on the "can" of the capacitor that says negative on it. To install an electrolytic cap, put the longer lead into the hole that is marked "+", and the shorter lead into the "-" hole. The can should fit flush with the board. Install Electrolytic caps C 9, C12 and C13. Be sure to correctly orient the capacitor and put the right cap in the right place.

The last capacitors to install are C17 and C18, the Silver Micas; They are the maroon caps. You should now have all caps installed.

The last board mounted part to install is RFC2, the 82 mH choke. Please don't sub this part, as Wayne selected it because it is shielded and is small in size for its high value.

Examine the board now. Make sure that you have filled in every part. You should not have any empty holes except where the connectors go. The next step is to check for solder bridges. If you have a magnifying glass use it to check the board to make sure there are no solder bridges making connections where it shouldn't.

Now it is time for you to finish the kit. The builder will have to supply the connectors that he prefers. Install them now. I use a BNC for the antenna connection, a 9V battery connector for power, a 1/8" jack for headphones and a 1/8" jack

## The Forty-9er: A 40 Meter Transceiver with 9 Volts

By Wayne Burdick, N6KR

14326thAve.

Belmont, CA 94002

Doug Hendricks found a batch of 7.040MHz crystals, and had no choice but to get someone to design a rig around them. In this article I'll describe a very simple 40m D-C (direct conversion) transceiver that I call the "Forty-9er," because it can run on a 9V battery. In the spirit of NorCal collaboration, Doug will do the PC layout, and part with his crystals at some reasonable price.

Another motivation for this rig was to improve performance over the D-C transceiver that some of us built at Dayton last year. The Forty-9er has a few more parts (about 1/3 as many parts as a NorCal 40), but as a result it is actually usable.

Features:

- \* Runs on any DC voltage from 7 to 12V
- \* Power output of roughly 250mW at 9 volts, 500mW @ 12V
- \* VXO covers about 5kHz (7.037 to 7.042 with 7.040MHz crystal)
- \* Full QSK - really helps when you're using such low power
- \* Very low current drain: 10mA receive, about 70mA transmit (@9V)
- \* Only one simple alignment step, and NO toroids

Circuit Details

Refer to the schematic. D1 is the product detector and VXO. To minimize AM broadcast and portable phone pickup (both are problems with direct conversion receivers), the input tuned circuit has a low L-C ratio. This increases the Q of the tuned circuit, and the small loss in signal is not a problem. On transmit, D 1 detunes the input tuned circuit and unbalances the mixer, preventing the transmitter from modulating the VXO signal.

JFET mute switch Q1 is used to provide full QSK. Q1 must be a low pinch-off voltage type (J309, J310, 2N5484, etc.) because the voltage at pin 4 of D1 is only about 4V. This detail is occasionally overlooked. For example, you'll see MPF102 mute switches used with NE602s running at 6V; even though an MPF102 can have a Vp of up to 8V; and may not be completely cut off on transmit.

Q1 is followed by a passive low-pass filter (RFC2, C10) and

for the key.

Next install the standoffs with 4-40 hardware. I use standoffs that are 1/4" x 4-40. You can get a nice assortment from Radio Shack. Mount the board in a case of your choice, and you are ready to do the simple alignment.

Connect an antenna that you know is resonant. THERE is NO protection for SWR in this rig. Hook up a 9V battery, plug in the headphones and listen to the signals. Tune around the band, you should get about 5kHz of tuning range. Find a good signal and peak C2 for best signal by ear. That is all there is to it. Your rig is ready. Connect to a dummy load and a watt meter and you should see about 200mW with key down. If you have problems, check for solder bridges and correct parts placement.

a simple, high-gain AF amplifier circuit (U2). RFC2 and C10 are quite large because they must resonate in the AF range (see parts list).

The VXO covers about 5kHz. To get the VXO output high and consistent, I used two tricks: (1) C4 is bigger than C5; (2) R4 was added to increase the oscillator bias a bit. Don't use these techniques in every '602 project, since they may degrade receiver performance. Also, since good crystal starting and low oscillator current drain are conflicting goals, don't expect to be able to increase the size of RFC6. At some point, your transmit power will drop dramatically at one end of the VXO trim cap.

The transmitter has only two stages. The 2N3904 is selfbiased for simplicity, and provides enough gain to drive the 2N3866 to around 200mW. The final operates class C, and is reasonably efficient. I could have used a class A final amp stage instead and possibly eliminated the low-pass filter, but I wanted to minimize current drain. This is a good strategy for operation from a 9V battery, which may provide only a hundred milliampere-hours (higher with alkaline or lithium).

Sidetone is not included, since it would have added another five or six parts. You can hear a soft buzz when you key the rig, though, which is acceptable if you're using a pushbutton key.

**Construction:**

If you use your own PCB or breadboard layout, here are some things to keep in mind: (1) in general, keep the RF chokes a good distance apart, or if you can't, use toroids; (2) keep lead lengths short; (3) use as much ground plane as possible.

There are many ways to improve on the design. You can change the QSK delay by changing C8 (with .002uF, you can hear between dits at 15WPM). If you want better low-pass filtering, add another L-network after C10 (82mH and 0.47uF). This will improve rejection of high-pitch signals but will increase insertion loss.

**Operation:**

You can use 7 to 16 volts with this rig, but put a heatsink on Q3 if you use over 12V. IMPORTANT: Since there is no SWR protection at the output, you MUST use a known, matched

antenna (or a 50-ohm dummy load) with this rig. If you use an antenna tuner, be sure you use an absorptive-type SWR bridge so that the final will see a reasonable load during tune-up. In-line SWR bridges provide no protection for the final.

The frequency shift from receive to transmit is very small—typically 100 Hz. The shift is in the downward direction, so when you call a station, make sure you're listening on the HIGH frequency side of zero beat. (There are two places you can set the VXO cap to listen to any particular station; use the lower-capacitance setting and you'll be on the high side.)

The rig can be used hand-held with a push-button code key. In the field, you'd just hook up a 33' piece of wire and toss it into a tree, and toss out a ground radial of the same length. Use #22 or larger stranded copper wire and a small, smooth fishing weight. Bring a backup antenna in the event that your tree was hungry.

**Conclusion:**

It's a nice change to build something so simple, and it really seems to work. On the day I built it, I worked Washington state and Michigan, both on the first call! It seemed deceptively easy, so I suspect conditions were good.

This is a good rig to take for emergencies or just for fun wherever you're going, since the whole station (including antenna wire and fold-up stereo headphones) will fit in your pocket.

The design is still preliminary, so please send me your comments and suggestions if you build one. (I can be reached by e-mail at burdick@interval.com.)

C3,8,11	.01 Mono	21RZ410	Mouser
15,16,19			
C4,17	270pF NPO	140-CD50S5-271J	Mouser
C5,14	82pF NPO	141-100N5-082J	Mouser
C6	4.5-60pF Trimmer		
C9	3.3uF/25 Elect.	208-SOV3.3	Mouser
C10	.47uF Mono	581-470NJ63	Mouser
C12	220uF/25 Elect.	208-25V220	Mouser
C13	22uF/25 Elect.	208-SOV22	Mouser
C17	270pF Silver Mica		
C18	470pF Silver Mica		
D1,2	1N4148		
C20	150pF	140-CD50N6-151K	Mouser
R1	1K or 2K Trimpot	323-5000-1K	Mouser
R2	10ohm		
R3	10M		
R4,6	120 ohm		
R5	56K		
R7	10K		
RFC1,5	2.2uH	43LS226	Mouser
RFC2	82mH	434-02-823J	Mouser
RFC3	1mH	43LSI03	Mouser
RFC4,6	15uH	43LSI55	Mouser
Q1	J309, J310, 2N5484		Mouser
Q2	2N3904		Mouser
Q3	2N3866		Mouser
UI	NE602AN		Digikey
U2	LM380-N		Digikey
U3	78L05 333-78L05AP		Mouser
X1	7.040 MHz Crystal		Norcal

**Parts List:**

C1	722pFNPO	141-100N5-022J	Mouser
C2	9-50pF Trimcap	24AA024	Mouser

**Misc. Parts:**

9V battery connector, 2 - 1/8" chassis mount phone jacks, 1 BNC chassis mount antenna connector, hookup wire, small case or cabinet of choice.

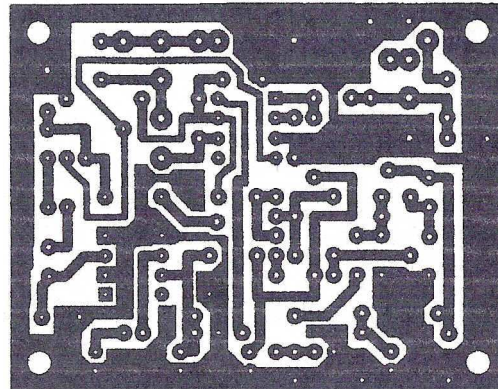
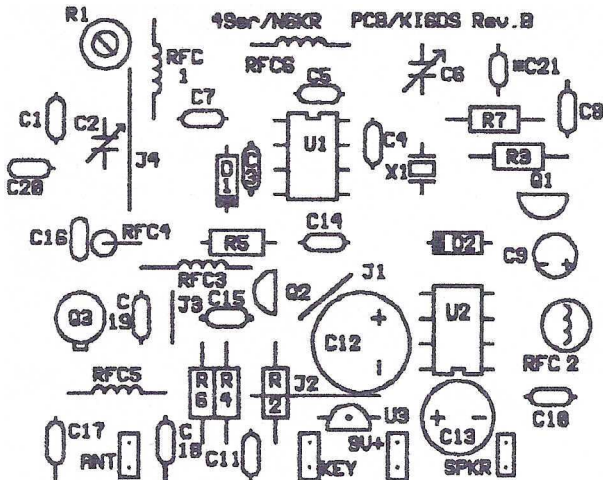

PCB Viewed from Bottom

**49er Parts Identification**

C1, C7 - 22pF NPO, Body tan in color



C21 = 5pF NPO, Body tan in color



C2 = 9-50 Trimcap, black body color with orange insert, or yellow body. Has 2 leads.



D1,2 = 1N4148, Orange body with black band at one end



C6 = Tuning Cap, 3-60pF, gray body color or orange-yellow body

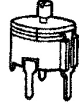

R1 = 1K or 2K Trimpot, black and gold in color

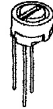

C3,8,11,15,16,19 = .01 Mono Cap, Tan in color



R2 = 10 ohm Resistor: Brown-Black-Black-Gold color code



C4 = 270pF NPO, Body tan in color



R3 = 10 M Resistor: Brown-Black-Blue-Gold color code



C5,14 = 82pF, Body gray in color



R4,6 = 120 ohm Resistor: Brown-Red-Brown-Gold color code



C9 = 3.3uF/50V Electrolytic, Light blue in color

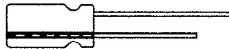

R5 = 56K Resistor: Green-Blue-Orange-Gold color code



C10 = .47uF Mono, Body blue in color



RFC 1,5 = 2.2uH: Red-Red-Gold-Black color code on green body

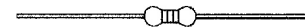

RFC2 = 82mH: 823J, Body Dark Gray

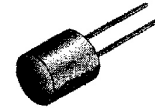

C12 = 220uF/16V Electrolytic, Body black in color

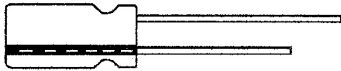

RFC3 = 1mH: Brown-Black-Red-Silver color code on green body

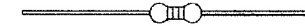

RFC4,6 = 15uH Brown-Green-Black-Silver color code on green body

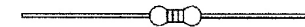

C13 = 22uF/35V Electrolytic, Body black in color

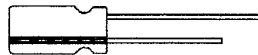

Q1 = 2N5484

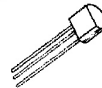

Q2 = 2N3904

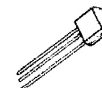

Q3 = 2SC799



C17 = 270pF Silver Mica, Body maroon in color



U1 = NE602AN



Pin 1

U2 = LM380N-8

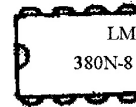

Pin 1

U3 = 78L05

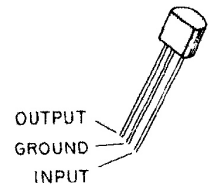

C18 = 470pF Silver Mica, Body maroon in color

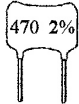

C20 = 150pF NPO, Body Tan in color



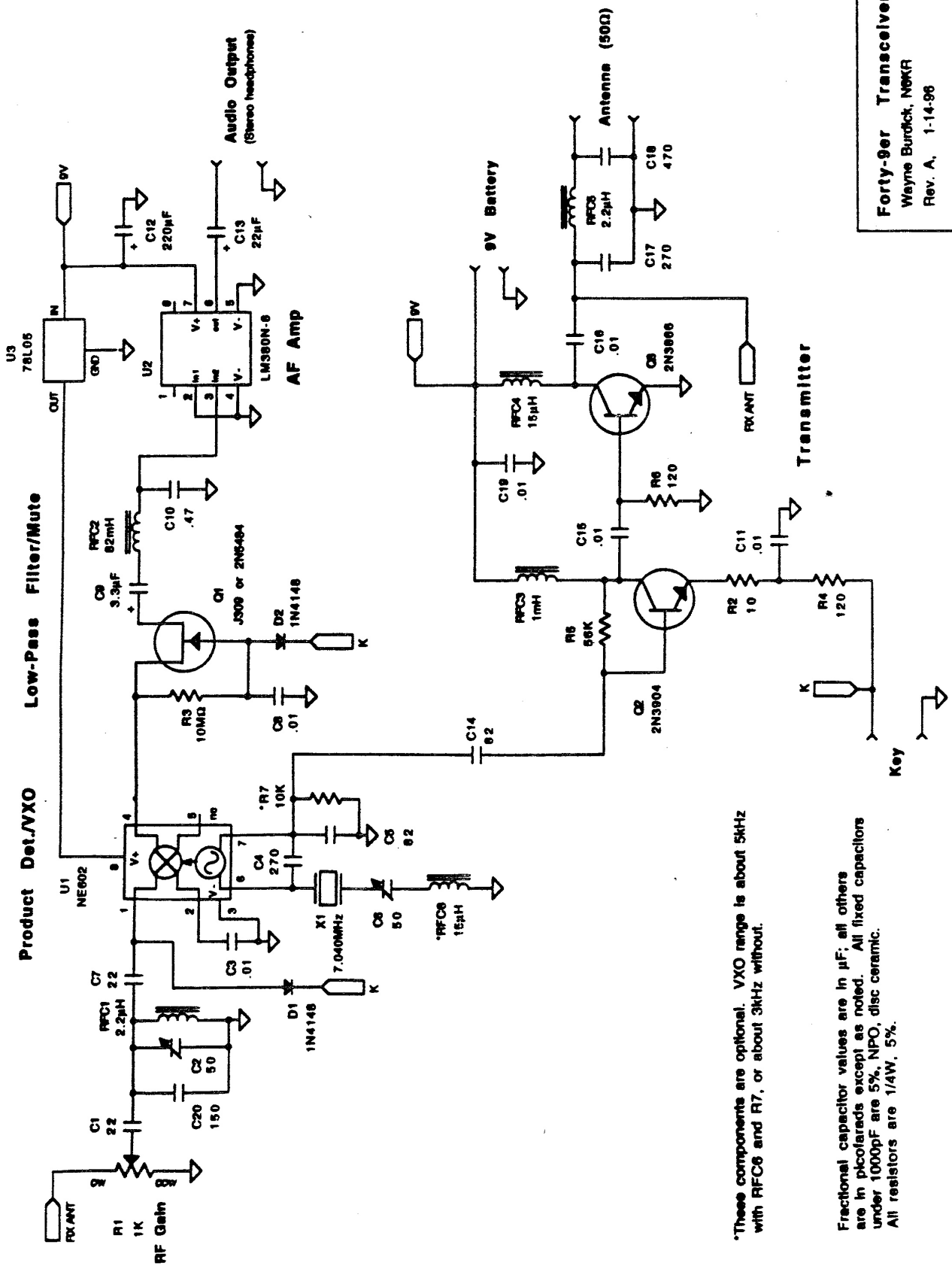

**Forty-9er Transceiver**  
 Wayne Burdick, N6KR  
 Rev. A, 1-14-96

\*These components are optional. VXO range is about 5kHz with RFC6 and R7, or about 3kHz without.

Fractional capacitor values are in  $\mu\text{F}$ ; all others are in picofarads except as noted. All fixed capacitors under 1000pF are 5% NPO, disc ceramic. All resistors are 1/4W, 5%.

Key